



HYDRAULIC OIL CLEANING SYSTEM



Oilmax



- ◆ Fine Filtration up to 1 μ
- ◆ Extend Oil Change Period
- ◆ Reduce Machine Downtime
- ◆ Prevent Production Loss
- ◆ Increase Hydraulic System Life
- ◆ Save Oil & Maintenance Cost

[Presentation](#)

[Animation](#)

[Working Video](#)

Save by *Extending Oil & Equipment Life*



Use Oilmax
Save Environment

Applications :

- ◆ Plastic & Rubber Components
- ◆ Automobile & Auto-components
- ◆ Paper, Packaging & Plywood Mfg.
- ◆ Tiles & Ceramics Mfg.
- ◆ Marine Equipments
- ◆ Cement & Steel Plants
- ◆ Mining & Earthmoving Equipments

Unique Three Stage Filtration Process

Stage 1 – High power rare earth magnetic filter to trap ferrous particles consumable free and reusable.

Stage 2 – Specially designed inverted rotor centrifuge which is consumable free and reusable. It will trap majority of contamination up to 1 micron

Stage 3 – Very fine depth filter to remove particles down to 0.1 micron and to absorb moisture



Stage 1



Stage 2



Stage 3

One Time Installation, Lifelong Savings

Working Principle

Centrifugal Oil Cleaner works on reaction turbine principle. Oil enters Centrifuge under pressure and escapes through tangentially opposite nozzles of rotor producing rotor speed upto 8000 RPM. The resultant Centrifugal force removes dirt from the oil, depositing it on the inner wall of rotor. Clean oil drains back to the oil tank by gravity. Centrifugal oil cleaner is completely consumable free, there is no filter element hence no recurring cost.

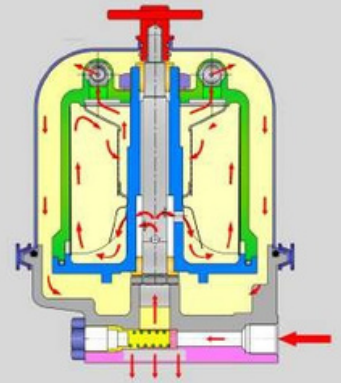

Filtration Result

Before Filtration



After Filtration



Schematic Diagram

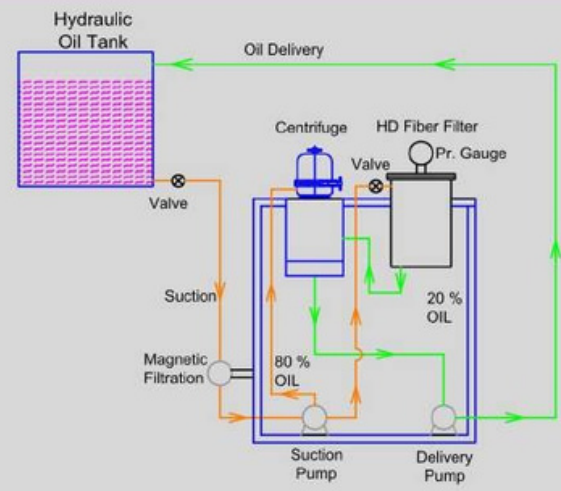

Hydraulic Oil Filter Unit

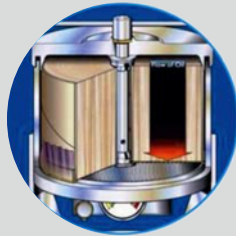

- Compact portable unit
- Filters down to 0.1 micron
- Moisture holding capacity 900cc
- Dirt holding capacity 600 grams
- Cleanliness : ISO 14/11, NAS 5-7

[Catalogue](#)



Our Valued Customers



Oilmax Systems Pvt. Ltd.

38/2/12, Narhe Dhayari Road, Narhe, Pune 411041 INDIA
 Tel. +91 7776078885, +91 9881895950, Email : mail@oilmax.co.in,
 Web : www.oilmaxsystems.com, www.centrifugaloilcleaner.com

